



## Mini Modular Rectangular Connectors

- High density up to 1000 signal Ø 0.60mm contacts.
- Modularity mixed signal, power, coaxial contacts.
- Clip contact retaining system.
- Metallic shell.
- Cable clamp 12 to 25mm.
- Centered jackscrew extractor.
- 5000 mating cycles with the threaded jackscrew.
- 15000 mating cycles with the 1/2 turn jackscrew.
- Contact safety : 1mm

“Hypertac® high density mini-modular connectors” use a concept system based on the building block principle. They offer a large range of combinations available in a single connector frame. Therefore, the user is capable of selecting the connector that fulfils the exact requirements with off-the-shelf components.

Two of the main advantages of the Hypertac® contact are its low insertion/extraction forces and pin & socket wiping action. In this application the user is able to assemble a significantly large number of contacts into a connector which is still able to mate and unmate smoothly and easily.

The H series can be built up for the following:

- Rack and panel applications
  - Standard
  - With keying system
  - With locking systems
  - With floating mounting
- Cable applications
  - Hooded with rounded or flat cable security clamps
  - With jack screws
- Programming applications

The system is composed of two basic elements: the modules and the frames.

1. The modules are the connector elements of the system. Contacts are housed in small plastic blocks. All contacts are removable for easy assembly and repair. The width of each module block is designated in units (1 unit = 2.54mm, 1/10 inch).

Module	P	H-E	NH	T	C	M	H	E	V
N-Unit	1	1	2	2	4	4	4	4	4
Capacity	5A	5A	1A	9A	25A	50A	5A	5A	50 v

2. The frames keep the modules in position. They range from a basic frame consisting of 2 side rails and 2 end caps to more complex versions with jackscrews, cable clamps, etc...

All frames are available in various lengths to conform to almost any combination of modules. Although any length is possible, we suggest ordering one of the standard lengths for optimum delivery and price. This can be accomplished by filling in any empty spaces with blank modules.

H series, specially designed connectors, provide high reactivity, flexibility and cost saving by eliminating the extra cost and delay of custom tooling.

Ordering Information

VALID FOR SIMPLE COMPOSITIONS (modules of same type)				H	C	-	5	01	13	40	19	
FAMILY												
HOUSING TYPE												
MODEL												
-	Standard model	M	DIN 43659 shell	Y	1/2 turn jackscrew							
B	Shielded EMC	N	Dielectric hood (plug only)									
L	Reinforced - Inox hood - (plug only)	R	Reversed polarity (consult us)									
JACKSCREW TYPE												
0	Single row without extractor jackscrew											
5	Single row with extractor jackscrew											
8	Single row with 1/2 turn jackscrew											
0	Double row without strengthened central bar											
5	Double row with strengthened central bar											
MODULE ARRANGEMENT												
01	Module P	14	Module NH	12	Module H	06	Module M	17	Module H-U			
16	Module H-E	02	Module T	07	Module C	15	Module V					
For mixed composition :fill in «H Module Configurator» formulary and send it to HYPERTAC SA												
CONNECTOR TYPE - POLARITY												
03	Plug*	04	Receptacle*	06	Extension*		* without contacts					
12	Female Plug	22	Female Receptacle	32	Female Extension							
13	Male Plug	23	Male Receptacle	33	Male Extension							
<b>Note: code 12, 23, 33 are only available with model R</b>												
TERMINAL STYLE												
20	Crimp	40	Solder	53	Wrap u 1.20							
30	Straight	51	Wrap u 0.60									
NUMBER OF PITCHES												
07 to 35	Single row (from 7 to 35 pitches)											
38 to A5	Double row (from 19 to 55 pitches)											
SHIELDED RING (Valid only for H-B plug)												
A	Ø 22mm	B	Ø 19mm	C	Ø 15mm							

**Module P**

■ Width is 1 unit

■ 10 Hypertac® removable signal contacts

■ Ø 0.60 mm contacts

**Male**

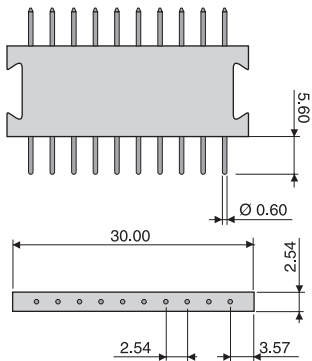

**Female**

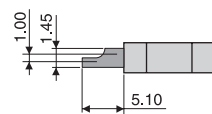
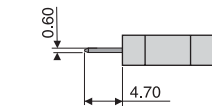
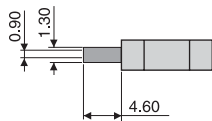
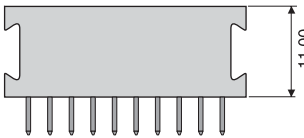

**Terminal Style**

**REF. 20**  
Crimp 22, 24 & 26 AWG  
Wire stripped back 4.4  
0061821-20ROG (pin)  
0060802-20RGO (socket)

**REF. 30**  
Straight solder dip  
0060821-30ROG (pin)  
0060822-30RGO (socket)

**REF. 40**  
Solder cup up to 22 AWG  
0060781-40ROG (pin)  
0060782-40RGO (socket)

**REF. 51**  
Wire wrap  
0060811-51ROG (pin)  
0060812-51RGO (socket)

**General Specifications**

Current Rating	5 amps
Contact Resistance	< 6 milliohms
Extraction Force	15 - 60 gr.
Contact Life Cycles	>100,000
Dielectric Withstanding Voltage	1200 V RMS
Insulation Resistance	> 5 x 10 <sup>3</sup> Megohms
Temperature Rating	-55°C +125° C
Insulator	Glass filled nylon
Contact Material	Copper alloy
Plating reference	Ni >1mm+Au> 0,25mm on mating surface only.

**Module designations**

Terminal style	Crimp	Straight dip solder	Solder cup	Wire wrap
Male	PMR	PMD	PMS	PMY
Female	PFR	PFD	PFS	PFY

Notes:

- For empty block, order **PH**
- Crimp contacts will be shipped unassembled

**Accessories**

- Crimp tool: M22520/2.01
- Positioner: SS-0060000028
- Extraction tool: SD-0060000006

**Module H-E**

■ Width is 1 unit

■ 10 Hypertac® removable signal contacts

■ Ø 0.60 mm contacts

*Currently in development  
(Consult us about availability)*

**Male**

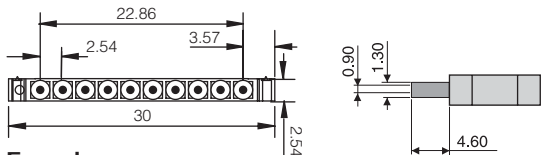
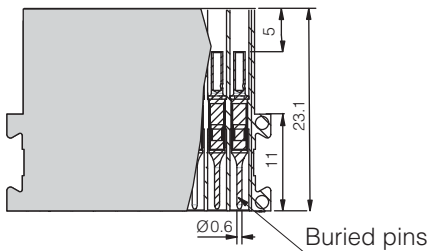

**Female**

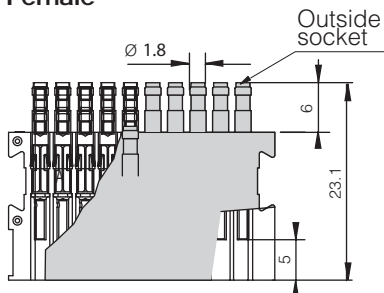

**Terminal Style**

**REF. 20**  
Crimp 22, 24 & 26 AWG  
Wire stripped back 4.4  
0061831-20ROG (pin)  
0061832-20RGO (socket)

**General Specifications**

Current Rating	5 amps
Contact Resistance	< 6 milliohms
Extraction Force	15 - 60 gr.
Contact Life Cycles	>100,000
Dielectric Withstanding Voltage	800 V RMS
Insulation Resistance	> 5 x 10 <sup>3</sup> Megohms
Temperature Rating	-55°C +125° C
Insulator	Glass filled nylon
Contact Material	Copper alloy
Plating reference	Ni >1mm+Au> 0,25mm on mating surface only.

**Module designations**

Terminal style	Crimp	Straight dip solder	Solder cup	Wire wrap
Male	H-EM	not available		
Female	H-EF	not available		

**Due to the module principle:**

- the female modules must be already fitted into the standard plug which will itself be equipped with other male modules
- the male modules must be already fitted into the standard receptacle which will itself be equipped with other female modules

Notes :

- For empty block, order **H-E**
- Crimp contacts will be shipped unassembled

**Accessories**

To be defined

Dimensions are in mm

### Module NH

■ Width is 2 units

■ 45 Hypertac® crimp contacts

■ Ø 0.40mm contacts

#### Male

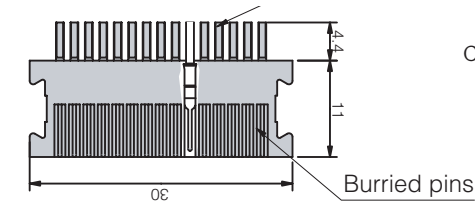

#### Terminal Style

**REF. 20**  
Crimp 26 AWG Wire stripped back 3.10  
YPN004-010H (pin)  
YSK004-020AH (socket)

#### General Specifications

Current Rating	1 amps
Contact Resistance	< 8 milliohms
Extraction Force	8.5 - 45 gr.
Contact Life Cycles	>100,000
Dielectric Withstanding Voltage	500 V RMS
Insulation Resistance	>10 <sup>3</sup> Megohms
Temperature Rating	-55°C +125° C
Insulator	Glass filled nylon
Contact Material	Copper alloy
Plating reference	Ni >1mm+Au> 0,25mm on mating surface only.

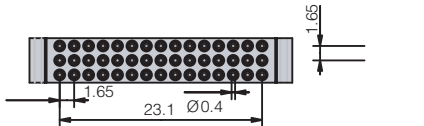

#### Female

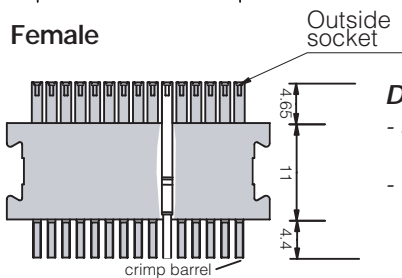

#### Due to the module principle:

- the female modules must be already fitted into the standard plug which will itself be equipped with other male modules
- the male modules must be already fitted into the standard receptacle which will itself be equipped with other female modules

Notes :

- For empty block, order **NH**
- Crimp contacts will be shipped unassembled

#### Accessories

- Crimp tool: M22520/2.01
- Positioner: Socket = T1974  
Pin = T1973
- Extraction tool: T1970

### Module T

■ Width is 2 units

■ 5 Hypertac® removable contacts

■ Ø 1.50mm contacts

#### Terminal Style

#### General Specifications

Current Rating	9 amps
Contact Resistance	< 2.5 milliohms
Extraction Force	35 -150 gr.
Contact Life Cycles	>100,000
Dielectric Withstanding Voltage	1800 V RMS
Insulation Resistance	> 5 x 10 <sup>3</sup> Megohms
Temperature Rating	-55°C +125° C
Insulator	Glass filled nylon
Contact Material	Copper alloy
Plating reference	Ni >1mm+Au> 0,25mm on mating surface only.

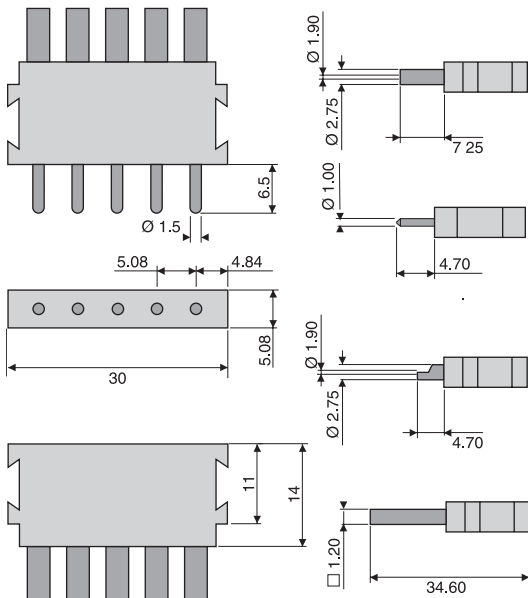

**REF. 20**  
Crimp 14, 16, 18 & 20 AWG  
Wire stripped back 7.20  
0150941-20ROG (pin)  
0150942-20RG0 (socket)

**REF. 30**  
Straight solder dip  
0151171-30ROG (pin)  
0151092-30RG0 (socket)

**REF. 40**  
Solder cup up to 13 AWG  
0150911-40ROG (pin)  
0150912-40RG0 (socket)

**REF. 53**  
Wire wrap  
0150921-53ROG (pin)  
0150922-53RG0 (socket)

#### Module designations

Terminal style	Crimp	Straight dip solder	Solder cup	Wire wrap
Male	TMR	TMD	TMS	TMY
Female	TFR	TFD	TFS	TFY

Notes :

- For empty block, order **TH**
- Crimp contacts will be shipped unassembled

#### Accessories

- Crimp tool: S-085
- Positioner: S-086
- Extraction tool: SD-015000005

Dimensions are in mm

### Module H

■ Width is 4 units

■ 2 Hypertac® high-voltage contacts

■ Ø 1.20 mm contacts

Male

Female

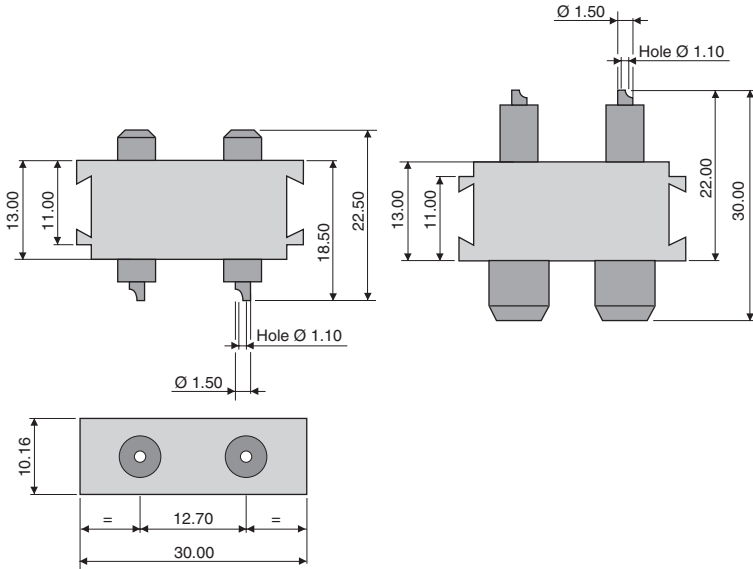

#### General Specifications

Current Rating	5 amps
Contact Resistance	< 3 milliohms
Extraction Force	40 -120 gr.
Contact Life Cycles	>100,000
Dielectric Withstanding Voltage	6000 V RMS
Insulation Resistance	> 5 x 10 <sup>3</sup> Megohms
Temperature Rating	-55°C +125° C
Insulator	Glass filled nylon
Contact Material	Copper alloy
Plating reference	Ni >1mm+Au> 0,25mm on mating surface only.

#### Module designations

Male	HM
Female	HF

Notes :

- For empty block, order MH

### Module C

■ Width is 4 units

■ 2 Hypertac® Power up to 25 amperes contacts

■ Ø 3.50mm contacts

Male

Female

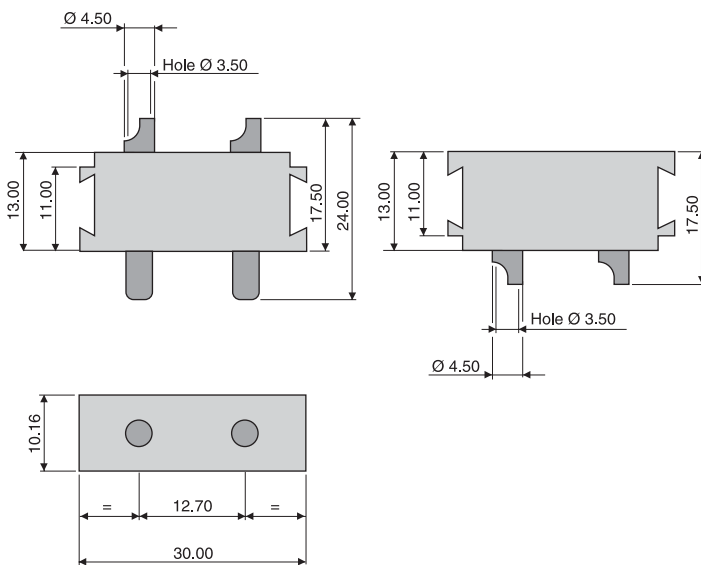

#### General Specifications

Current Rating	25 amps
Contact Resistance	< 0.80 milliohms
Extraction Force	250 -1000 gr.
Contact Life Cycles	>100,000
Dielectric Withstanding Voltage	5000 V RMS
Insulation Resistance	> 5 x10 <sup>3</sup> Megohms
Temperature Rating	-55°C +125° C
Insulator	Glass filled nylon
Contact Material	Copper alloy
Plating reference	Ni >1mm+Au> 0,25mm on mating surface only.

#### Module designations

Male	CM
Female	CF

Notes :

- For empty block, order MH

Dimensions are in mm

### Module M

- Width is 4 units
- 2 Hypertac® Power up to 50 amperes contacts
- Ø 3.50mm contacts

**Male**

**Female**

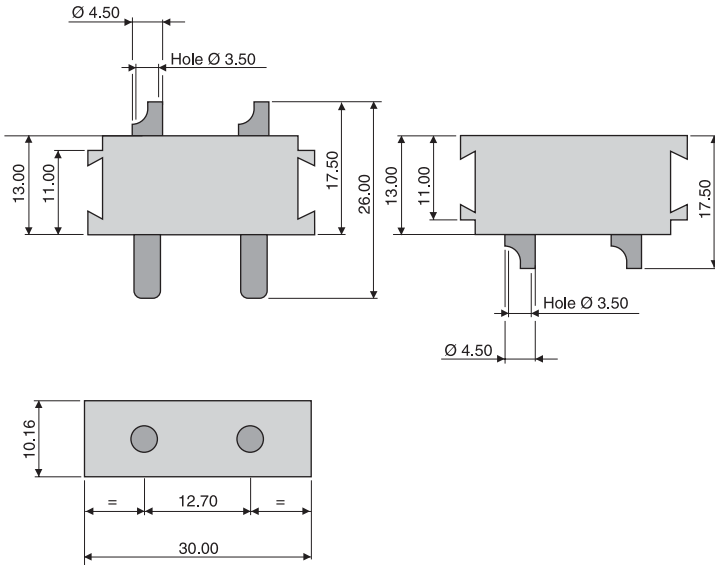

**General Specifications**

Current Rating	50 amps
Contact Resistance	< 0.60 milliohms
Extraction Force	1370 -2500 gr.
Contact Life Cycles	>100,000
Dielectric Withstanding	
Voltage	5000 V RMS
Insulation Resistance	> 5 x 10 <sup>3</sup> Megohms
Temperature Rating	-55°C +125° C
Insulator	Glass filled nylon
Contact Material	Copper alloy
Plating reference	Ni >1mm+Au> 0,25mm on mating surface only.

**Module designations**

Male	MM
Female	MF

Notes :

- For empty block, order **MH**
- Crimp contacts will be shipped unassembled

### Module H-U

- Width is 5 units

**Currently in development**  
(Consult us about availability)

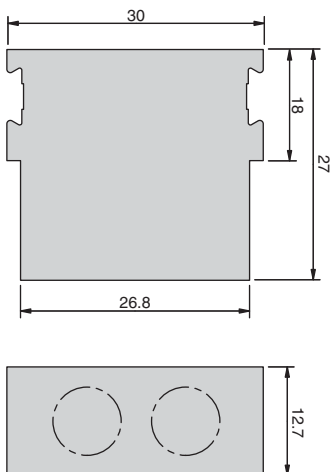

**UNIVERSAL MODULE**

Module without cavities for specific customer's applications. Several modules could be assembled together to increase width and to make enlarged cavities following customer wishes. Example shown on hereunder drawing.

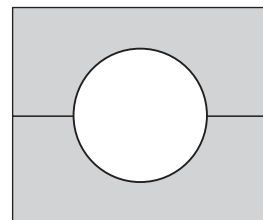

Notes :

- Width can be reduced on request
- For contacts, contacts arrangements, cavities feasibility and P/N please consult us.

Module V-R & V-S

- Width is 2.5 units
- 4 Hypertac® contacts (on both signal & ground)

Male

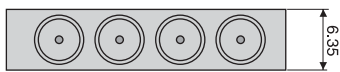
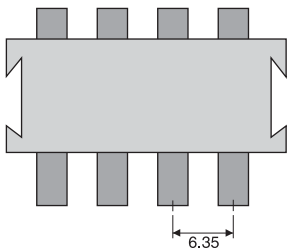

Terminal Style

Ref.20(Crimp) Ref.40(Solder)

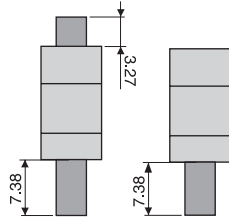

Female

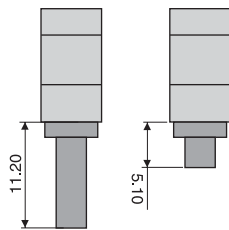
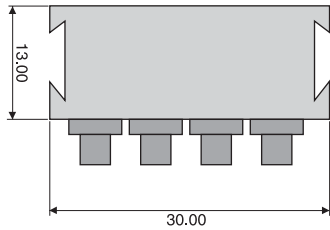

General Specifications COAXTAC

Nominal impedance	50 ohms
Frequency Range	DC 3 GHz with RG316 DC 18 GHz with RG405.
Temperature Rating	-55°C to 125°C
Materials	Brass Beryllium Copper PTFE Fluorocarbon
Center Contacts	Gold over nickel
Housings	Over copper
Wire	Gold over nickel
Voltage Standing Wave Ratio	(DC to 3GHz) 1.20: 1 Max. (based on RG405 semi rigid cable) (3GHz to 18GHz) 1.50: 1 Max.
RF Transmission Loss	0.50 dB Max.@18 GHz
Insulation Resistance	5,000 megohms min.
Dielectric Withstanding Voltage	500 VRMS
Contact Resistance inner Contact	8 milliohms Max.
Contact Resistance outer Contact	2 milliohms Max.
Extraction Force	42.5 - 170g Max., 85g average
Contact life cycles	> 25,000

Module	Contact	Cable
VMR	YCX0315-004H	RG316
VMRDB	YCX0315-018H	RG316DB
VFR	YCX0315-002AH	RG316
VFRDB	YCX0315-019AH	RG316DB
VMS	YCX0315-003H	RG405 or T-Flex405
VFS	YCX0315-001AH	

Accessories

Inner contact	Outer contact
Crimp tool: M22520/2.01	Crimp tool: M22520/10.01
Positioner: T1957	Die Set: T1958 (RG316) T2019 (RG316DB)
Extraction tool: T1982	

Cabling notice

	crimp (R) & (R1)	Solder (S)	
Cable	RG316& RG316DB	RG405	T-Flex 405
Socket:	S-50302	S50301	S50307
Pin:	S-50304	S50303	S50308

Module V-P

- Width is 2.5 units
- 4 Hypertac® contacts (on both signal & ground)

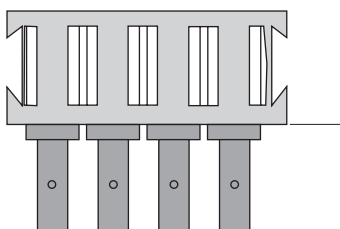
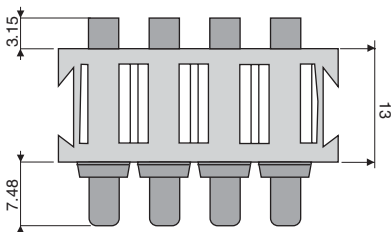

General Specifications

Current Rating	25 amps
Contact Resistance	< 1.5 milliohms
Extraction Force	85 - 482 gr.
Contact Life Cycles	>100,000
Dielectric Withstanding Voltage	500 V RMS
Insulation Resistance	>10 <sup>4</sup> Megohms @ 500 VDC
Temperature Rating	-55°C +105° C
Insulator	Nylon
Contact Material	Copper alloy
Plating (on mating surface only.)	Ni > 1mm+Au > 0,25mm

Contact PN

Module	Contact
VMS	YCX025-024H
VFS	YCX025-031AH

Accessories

Crimp tool:	M309
Positioner:	T1981
Extraction tool:	T1982

Dimensions are in mm

Frame HC up to 320 contacts

Plug

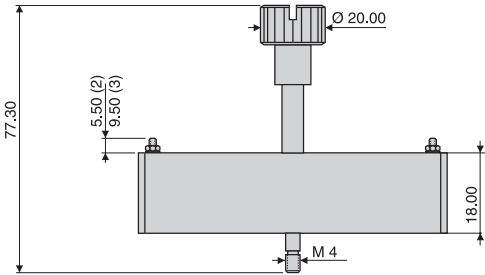
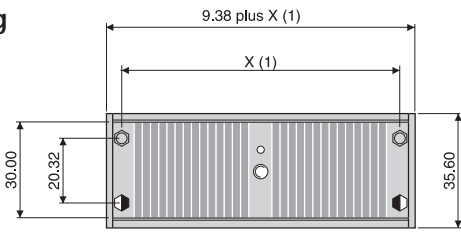

SEQUENCE OF MODULES

Receptacle

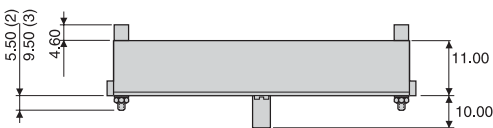
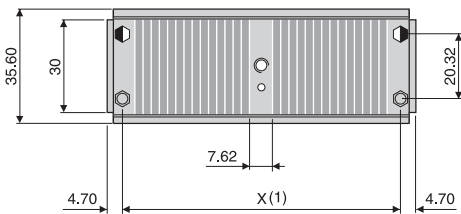

- Jackscrew extractor
- Allow 3 units for jackscrew
- Single row, rack & panel with keys
- Built-in pin protection
- 36 possible keying combinations
- Standard sizes: 7, 11, 15, 19, 23, 27, 31 & 35 unit lengths.
- Up to 320 contacts on 2.54 x 2.54 centers
- Mated length 68.50

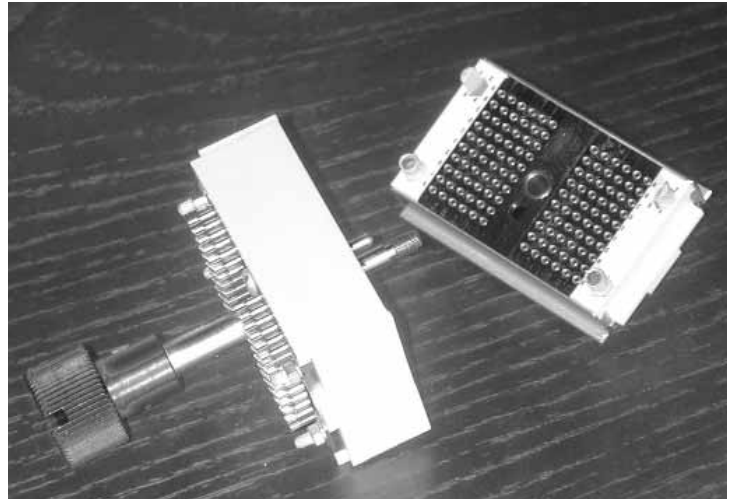

Notes :

- (1) See panel mounting dimensions page
- (2) Standard length for p.c. boards
- (3) For thicker chassis, specify longer studs consult us
- See ordering information, page

Frame HB up to 350 contacts

Plug

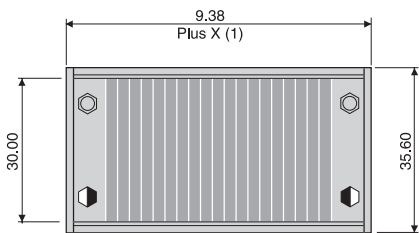

SEQUENCE OF MODULES

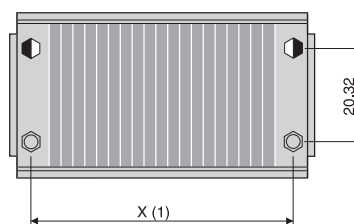

Receptacle



- Single row, rack and panel with keying
- Built-in pin protection
- 36 possible keying combinations
- Standard sizes: 7, 11, 15, 19, 23, 27, 31 & 35 units lengths
- Up to 350 contacts on 2.54 x 2.54 centers
- Mated length 23.50

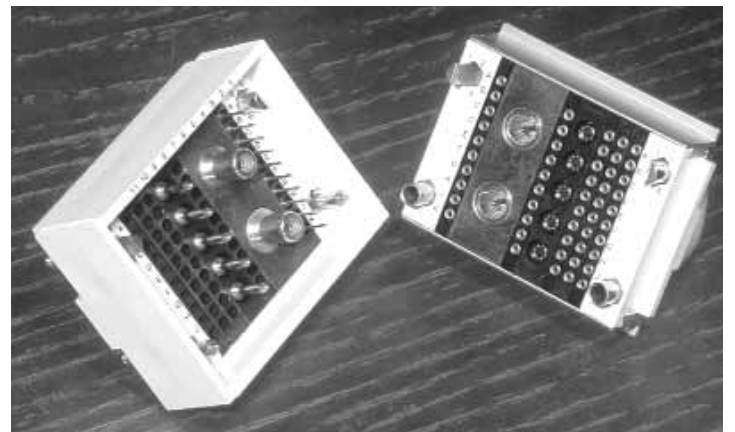

Notes :

- (1) See panel mounting dimensions page
- See ordering information page



Frame HD up to 350 contacts

Plug

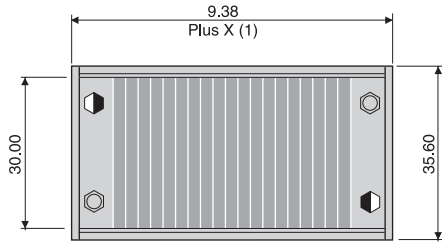

SEQUENCE OF MODULES

Receptacle

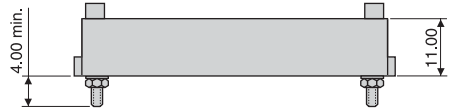
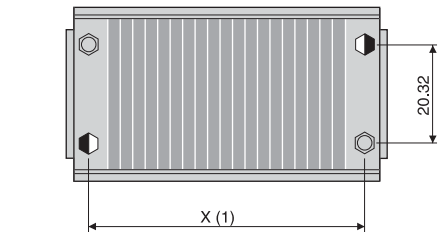

- Push, 1/4 turn locking hardware
- Single row, rack and panel with keying
- Built-in pin protection
- 36 possible keying combinations
- Standard sizes: 7, 11, 15, 19, 23, 27, 31 & 35 unit lengths
- Up to 350 contacts on 2.54 x 2.54 centers
- Mated length 23.50

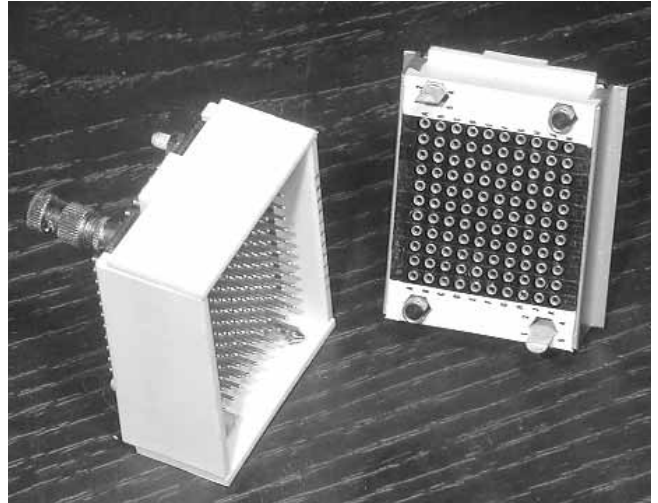

Notes:  
 (1) See panel mounting dimensions page  
 See ordering information page

Frame HG up to 350 contacts

Plug

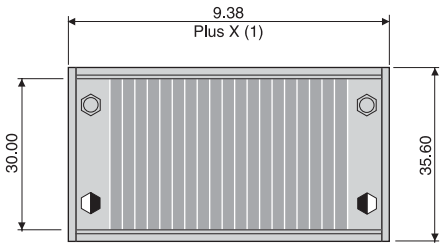

SEQUENCE OF MODULES

Receptacle

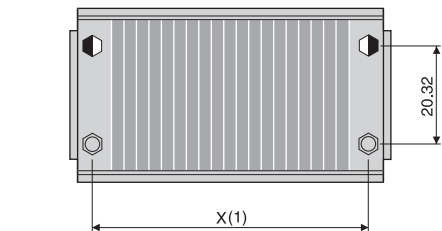

- Float mounting [Max. radial play 0.60]
- Single row, rack and panel with keying
- Built-in pin protection
- 36 possible keying combinations
- Standard sizes: 7, 11, 15, 19, 23, 27, 31 & 35 unit lengths
- Up to 350 contacts on 2.54 x 2.54 centers
- Mated length 25.20

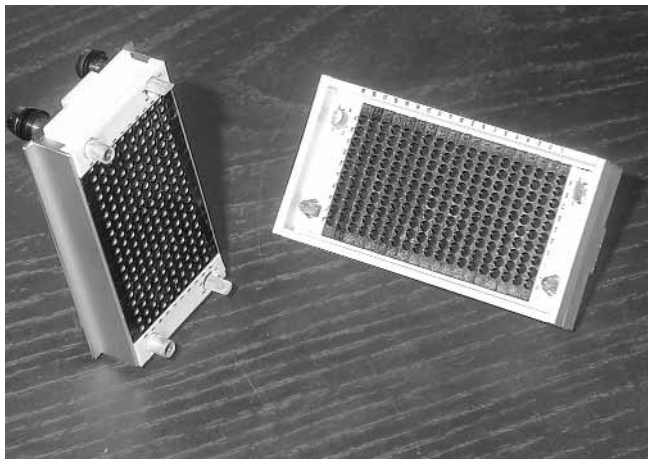

Notes:  
 (1) See panel mounting dimensions page  
 See ordering information page

Dimensions are in mm

### Frame HH up to 350 contacts

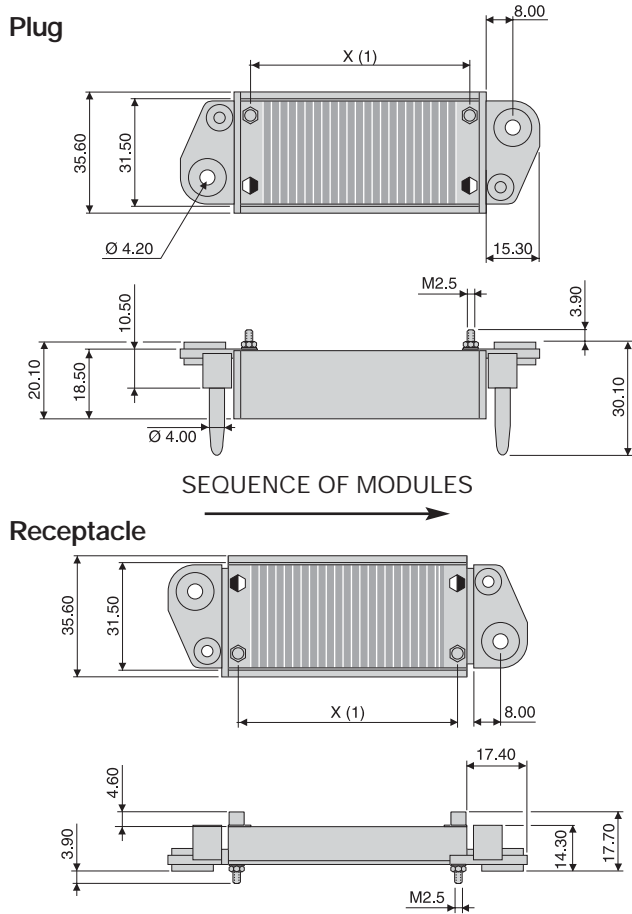

- Float mounting with heavy duty guides
- Max. radial play 1.25
- Single row, rack and panel with keying
- Built-in pin protection
- 36 possible keying combinations
- Standard sizes: 7, 11, 15, 19, 23, 27, 31 & 35 unit lengths
- Up to 350 contacts on 2.54 x 2.54 centers
- Mated length 26.50

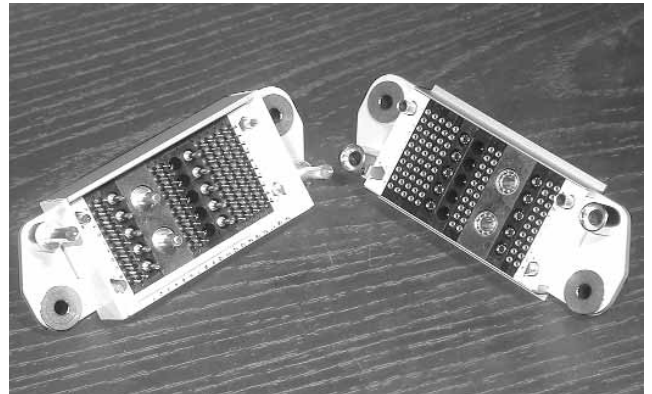

Notes:  
 (1) See panel mounting dimensions page  
 See ordering information page

### Frame HJ Plug with up to 320 contacts

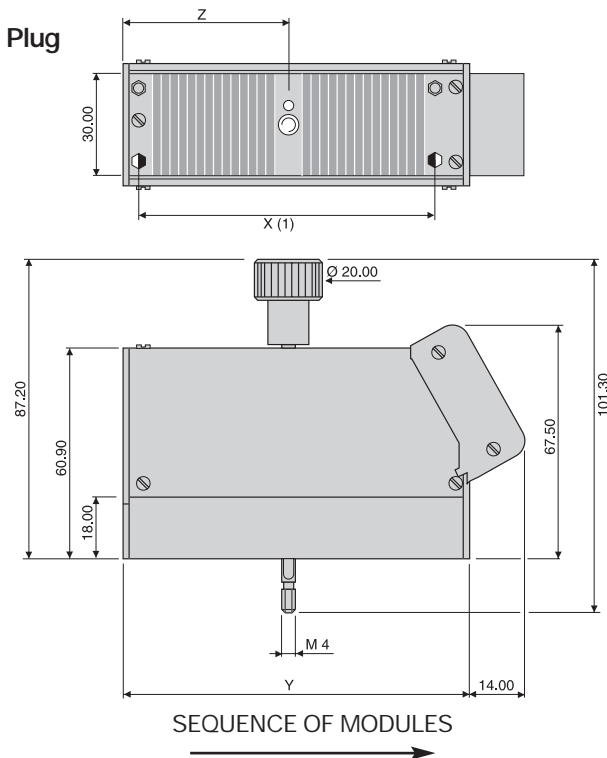

- Hooded with cable clamp Ø12.5 to 25mm
- Jackscrew extractor
- Allow 3 units for jackscrew
- Single row, rack and panel with keying
- Built-in pin protection
- 36 possible keying combinations
- Standard sizes: 11, 15, 19, 23, 27, 31 & 35 unit lengths
- Cable clamp will hold 80 to 320 conductors of 22 to 28 AWG
- Plug HJ mates with receptacle type HC or extension HJ
- Up to 320 contacts on 2.54 x 2.54 centers
- Mated length 92.50

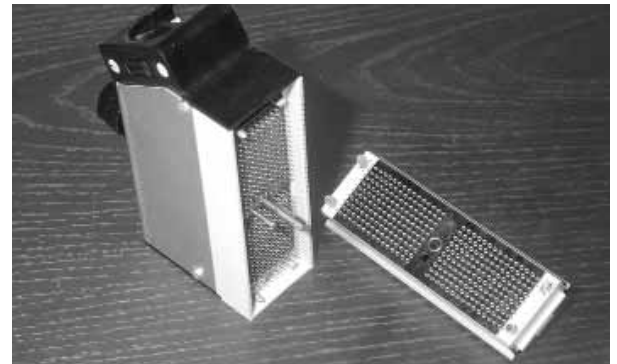

Notes:  
 (1) See panel mounting dimensions page  
 See ordering information page  
 - Mating face cover H--A  $\underbrace{\hspace{1cm}}_{n \text{ units}}$

Units	11	15	19	23	27	31	35
Y	50.64	60.80	70.96	81.12	91.28	101.44	111.60
Z	22.47	27.55	32.63	37.71	42.79	47.87	52.95

Dimensions are in mm

Frame HJ extension with up to 320 contacts

Extension

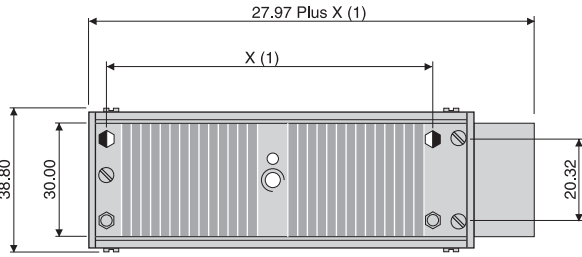

SEQUENCE OF MODULES

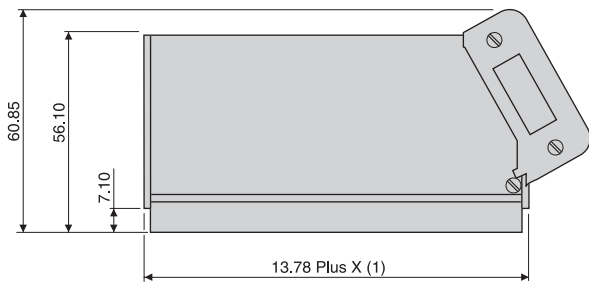

- Hooded with cable clamp Ø12.5 to 25mm
- Jackscrew extractor
- Allow 3 units for jackscrew
- Single row, rack and panel with keying
- Built-in pin protection
- 36 possible keying combinations
- Standard sizes: 11, 15, 19, 23, 27, 31 & 35 unit lengths
- Cable clamp will hold 80 to 320 conductors of 22 to 28 AWG
- Mates with plug type HJ
- Up to 320 contacts on 2.54 x 2.54 centers
- Mated length 142

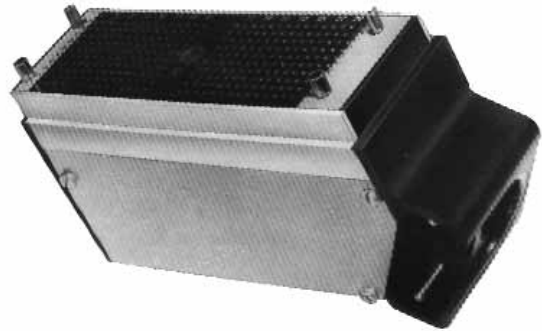

Notes:

- (1) See panel mounting dimensions page
- See ordering information page

Frame HK up to 320 contacts

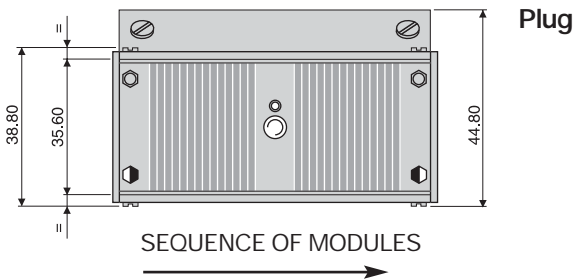

SEQUENCE OF MODULES



- Hooded with cable clamp Ø12.5 to 25mm
- Jackscrew extractor
- Allow 3 units for jackscrew
- Single row, rack and panel with keying
- Built-in pin protection
- 36 possible keying combinations
- Standard sizes: 7, 11, 19, 23, 27, 31 & 35 unit lengths
- Cable clamp will hold 40 to 320 conductors of 22 to 28 AWG
- Mates with receptacle type HC
- Up to 320 contacts on 2.54 x 2.54 centers
- Mated length 92.50

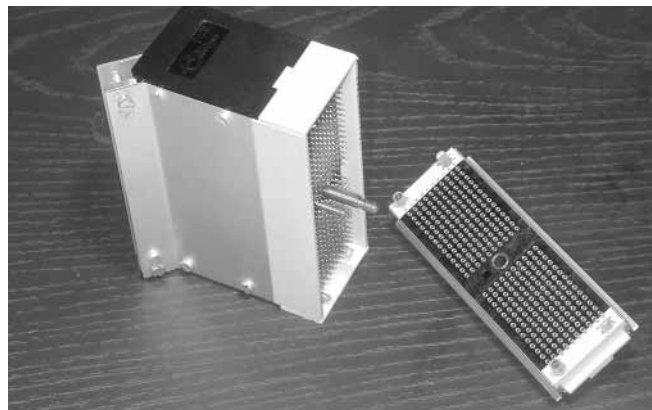
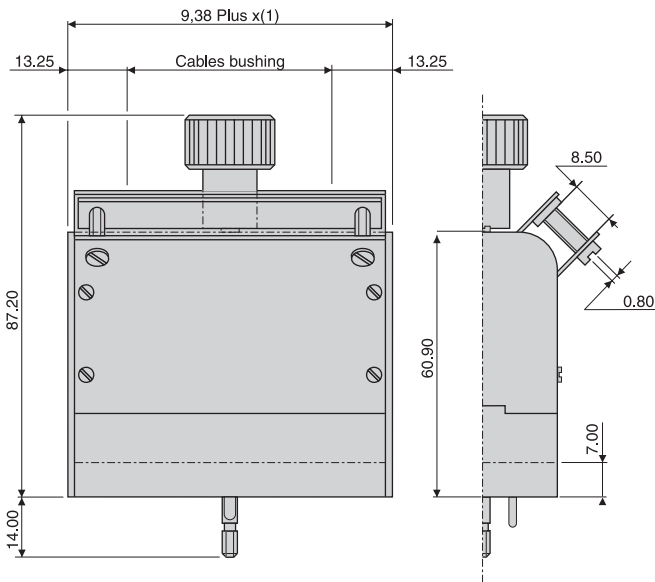

Notes:

- (1) See panel mounting dimensions page
- See ordering information page

Dimensions are in mm

Frame HR up to 320 contacts

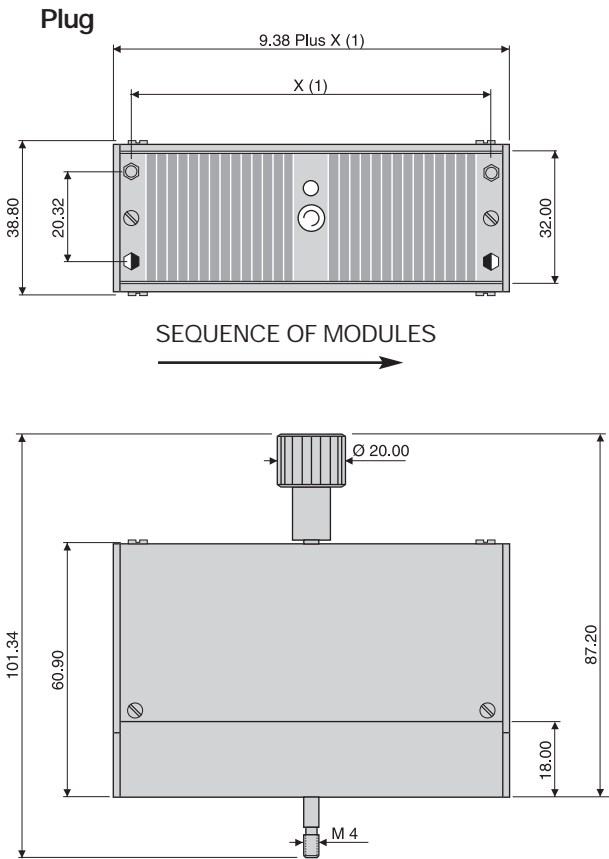

- Hooded for programming applications
- Jackscrew extractor
- Allow 3 units for jackscrew
- Single row, rack and panel with keying
- Built-in pin protection
- 36 possible keying combinations
- Standard sizes: 7, 11, 15, 19, 23, 27, 31 & 35 unit lengths
- Mates with receptacle type HC
- Up to 320 contacts 2.54 x 2.54 centers
- Mated length 92.50



- Notes:
- (1) See panel mounting dimensions page
  - See ordering information page
  - Mating face cover H<sub>---</sub>A  $n$  units

Frame HOM up to 585 contacts

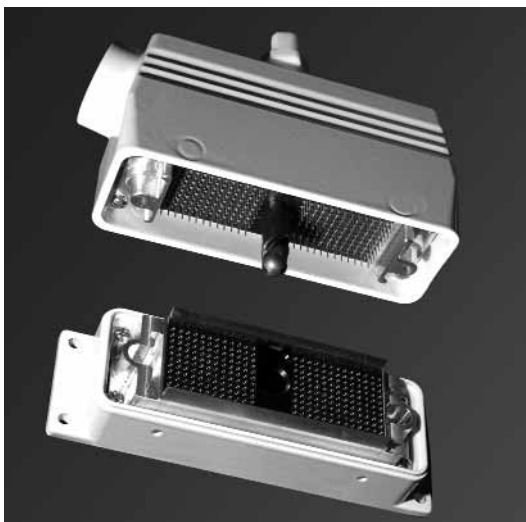

- Ruggedized version using H modules in DIN 43652 metal panel housings & hoods. Frame for modules is made from Aluminium.
- 3 sizes of shell are proposed
- Heavy duty environment with high density of H series.
- Coaxtac module compatible with HOM design.
- Male contacts protected by the plug design
- 7 module size can accept 260 «HC» 0.6 mm diameter contacts & 585 «HC» 0.4 mm diameter contacts.
- Half turn quick disconnect locking system.
- Medical white colour on request.
- Option: shielding.

*Currently under development  
(Consult us about availability)*

## 1/2 turn quick disconnect mini-module connector

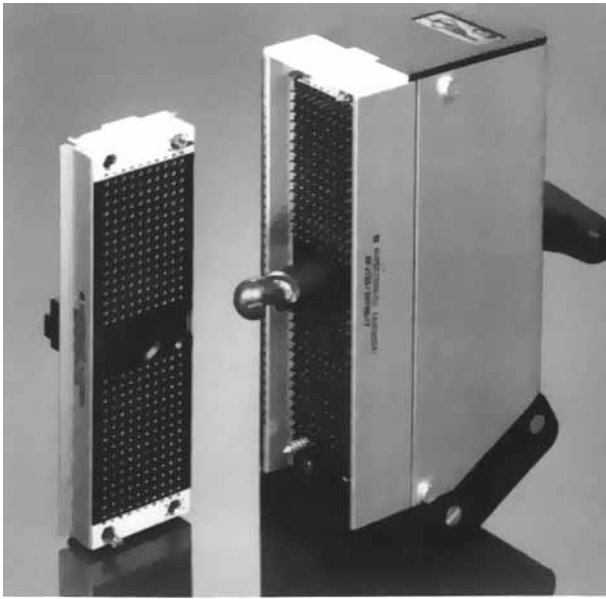

- 180° quick turn jack provides >15,000 mating cycles
- Great for test equipment, burn-in stands, security systems, medical equipment, etc...
- <1 second mating/unmating operation
- Crimp, solder cup, dip solder, and wire wrap® terminations
- Provides 20-320 contacts in a single mating
- 5 to 50 amperes contact mixed to your needs
- Built-in pin protection
- Standard Frame sizes: 11, 15, 19, 23, 27, 31 & 35 unit lengths.

Notes:

- (1) Standard length for p.c. boards
- (2) For thicker chassis, specify longer studs consult us
  - HCY or HJY plug mates with HCY receptacle
  - See ordering information page

HCY frame

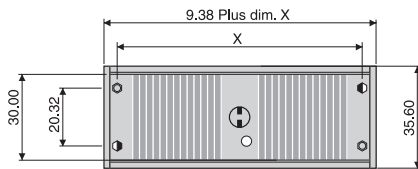

HJY frame

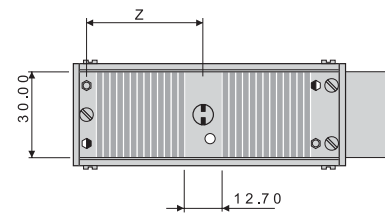

Plug

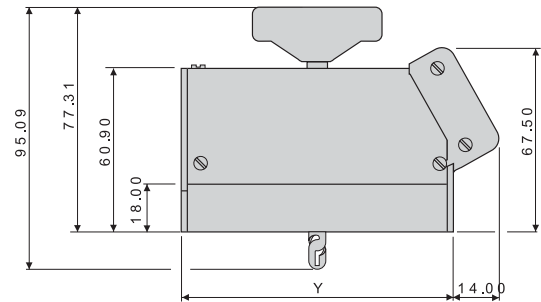
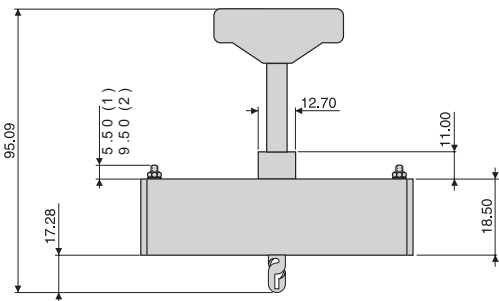

Receptacle HCY

SEQUENCE OF MODULES

SEQUENCE OF MODULES

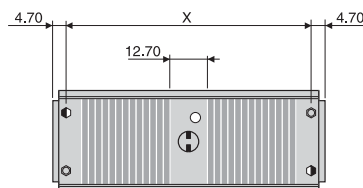
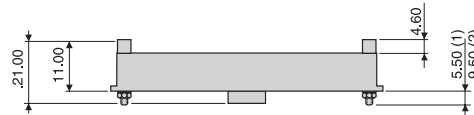

Units	11	15	19	23	27	31	35
X	35.56	45.72	55.88	66.04	76.20	86.36	96.52
Y	50.64	60.80	70.96	81.12	91.28	101.44	111.60
Z	22.47	27.55	32.63	37.71	42.79	47.87	52.95

Dimensions are in mm

Frame HL up to 1000 contacts

- Jackscrew extractor takes 5 modules space only for 35 to 55 unit lengths
- Double row, rack and panel with keying
- Built-in pin protection
- 36 possible keying combinations
- Standard sizes: 19, 23, 27, 31 & 35 to 55 unit lengths
- Up to 1000 contacts on 2.54 x 2.54 centers
- Mated length 110

Notes :

- (1) See panel mounting dimensions page
- (2) Standard length for p.c. boards
- (3) For thicker chassis, specify longer studs consult us
  - See ordering information page
  - Mating face cover H\_-- 284

$n$  units

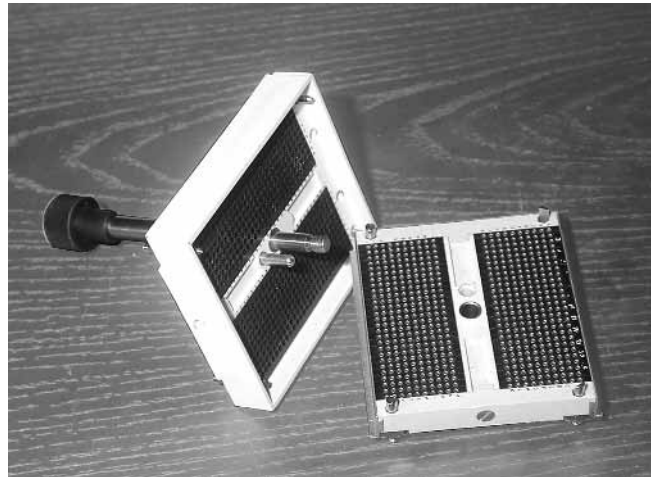

Plug

19 to 31 unit lengths

Receptacle

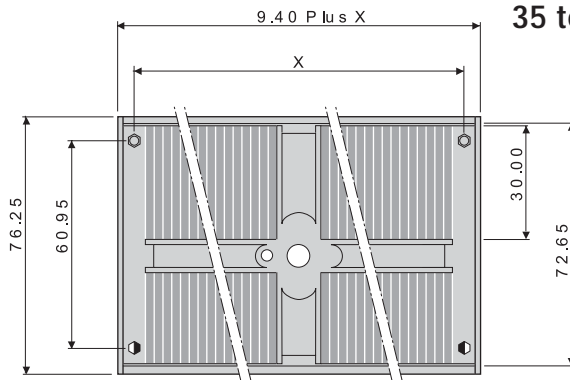
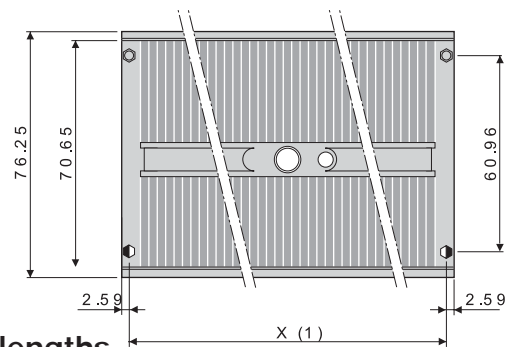
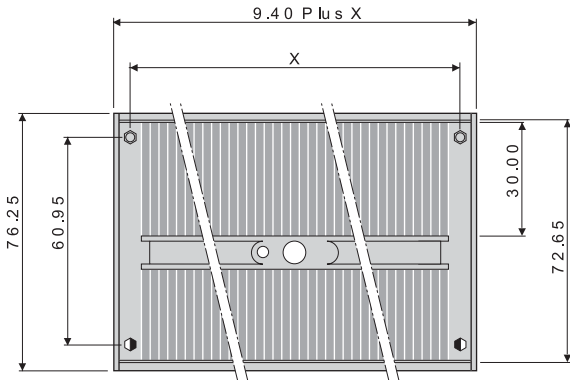

35 to 55 unit lengths

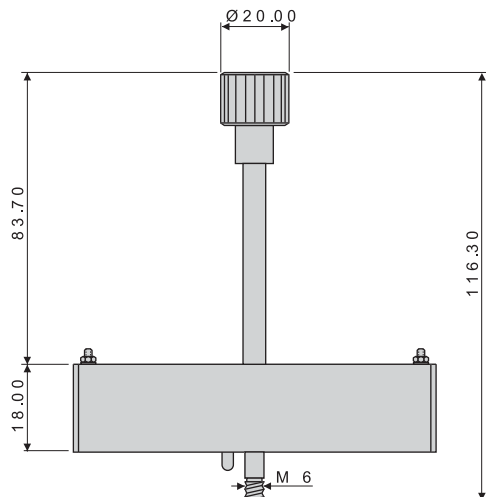
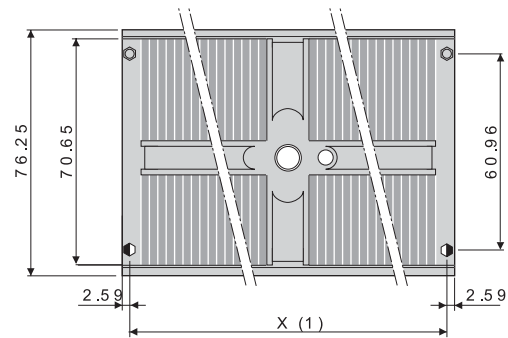

Sequence of modules view from receptacle mating side

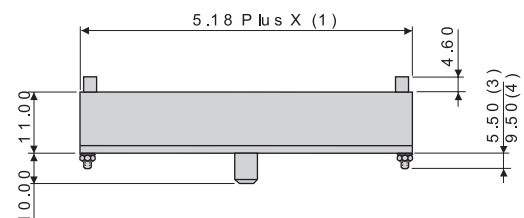

Dimensions are in mm

Frame HM up to 1000 contacts



- Hooded with cable clamp Ø16 to 50mm
- Jackscrew extractor takes 5 modules space only for 35 to 55 unit lengths
- Double row, rack and panel with keying
- Built-in pin protection
- 36 possible keying combinations
- Standard sizes: 19, 23, 27, 31 & 35 to 55 unit lengths
- Mates with receptacle type **HL**
- Up to 1000 contacts on 2.54 x 2.54 centers
- Possible double cable clamp, consult us
- Mated length 110

Plug

19 to 31 unit lengths

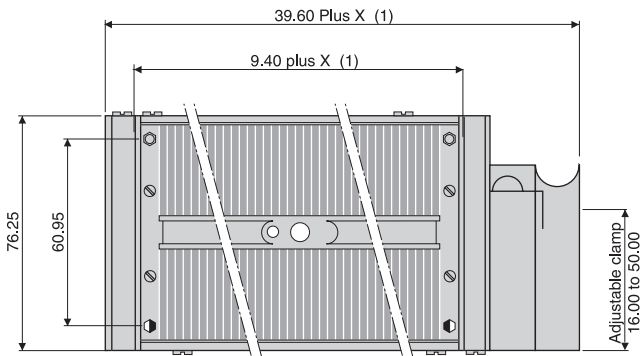

35 to 55 unit lengths

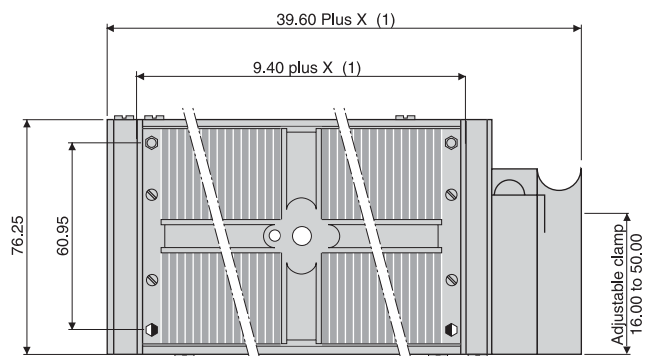

Sequence of modules view  
from plug mating side

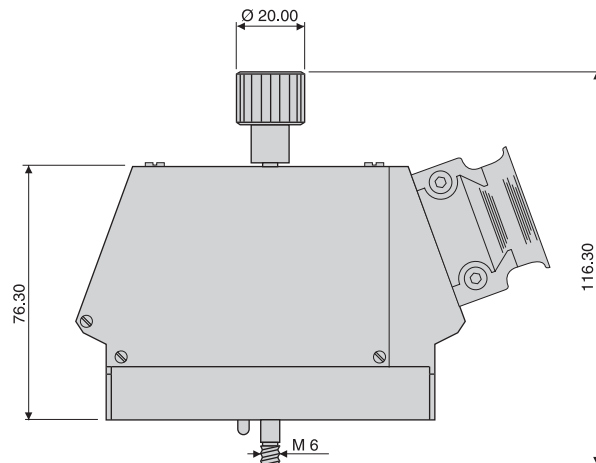
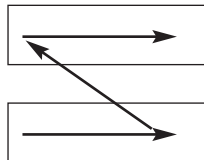

Notes :  
 (1) See panel mounting dimensions page  
 - See ordering information page  
 - Mating face cover H\_-- 284  
     └─ n units

Dimensions are in mm

Frame HJB

- Jackscrew extractor takes 3 modules space
- 1/2 turn jack takes 5 modules space
- Single row, rack and panel with keying
- Built-in pin protection
- 36 possible keying combinations
- Standard sizes: 07, 11, 15, 19, 23, 27, 31 & 35 unit lengths
- Up to 320 contacts on 2.54 x 2.54 centers
- Mated length 92.5

General Specifications

Effective shielding	> 40 dB to 200 MHz
Temperature Rating	-55°C to 125°C
Materials	
Guiding, coding and locking system	Stainless steel
Central polarisation system	Stainless steel
Frame	Anodized aluminium, PBT, Polyamide, polycarbonate
Mating and unmating life cycles	5,000 with jackscrew 15,000 with 1/2 turn jack
Sinusoidal vibrations	10Hz/2,000Hz-20g
Electrical discontinuity	< 20ns
Contact safety from extraction	1mm
Corrosion withstanding	96H (5% NaCL)

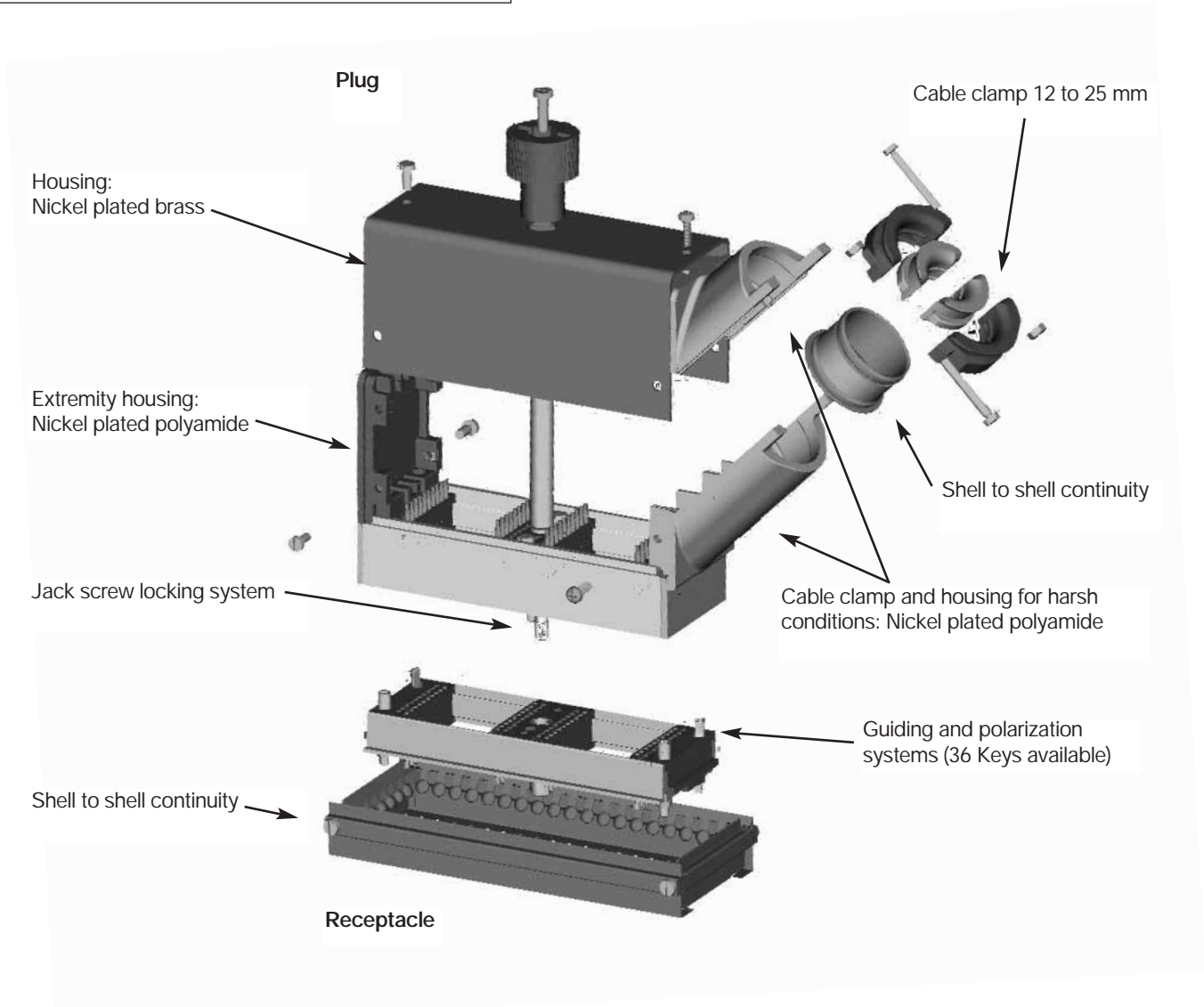
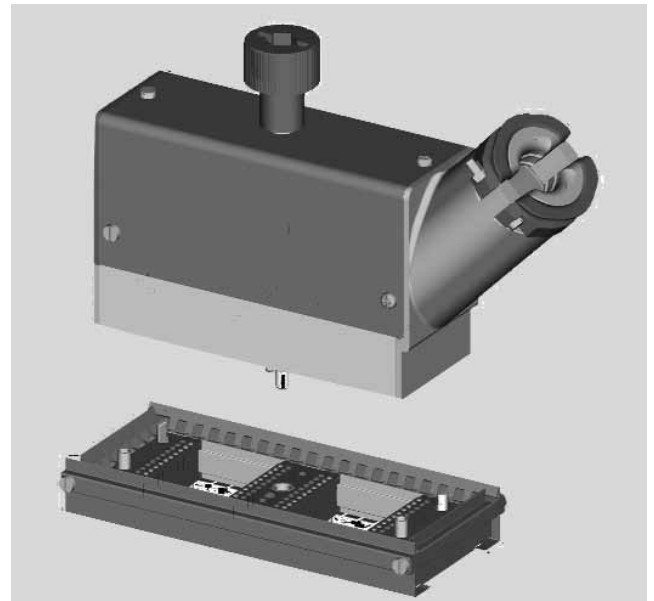

Dimensions are in mm



Frame HJB

Plug

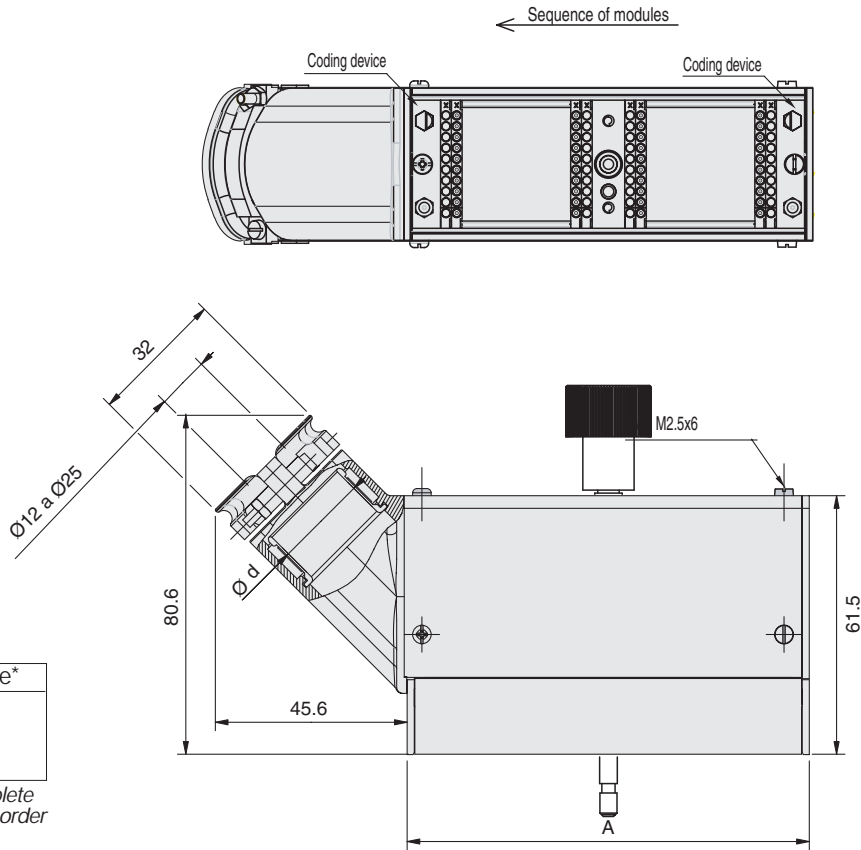

Ø d	code*
22	A
19	B
15	C

\*: code to complete the reference to order

n/units	A
07	34.67
11	44.83
15	54.99
19	65.15
23	75.31
27	85.47
31	95.63
35	105.79

Frame HCB

Receptacle

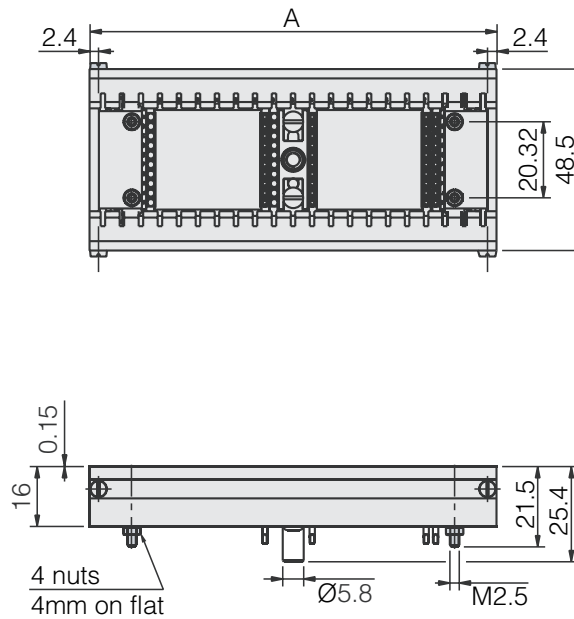

n/units	A
07	34.67
11	44.83
15	54.99
19	65.15
23	75.31
27	85.47
31	95.63
35	105.79

Notes :  
- See ordering information page

Dimensions are in mm

### Keying combination

Mating side receptacle view

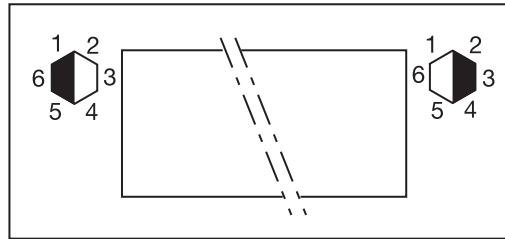

———— Sequence of modules

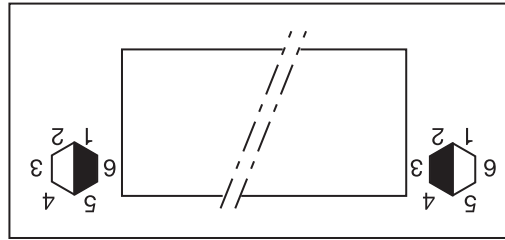

Mating side plug view

### Sequences of modules

Simple row

Double row

Plug view from cabling side

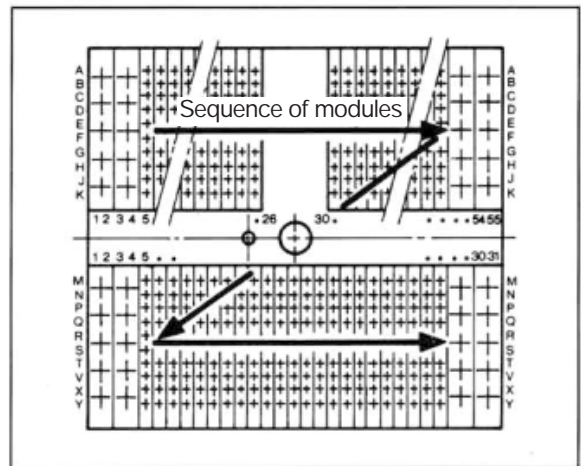
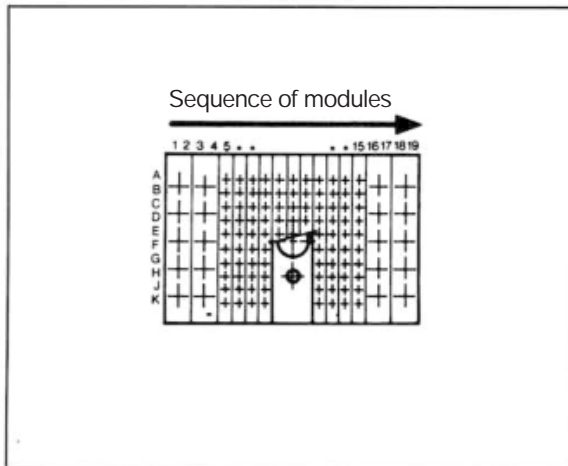

Receptacle view from cabling side

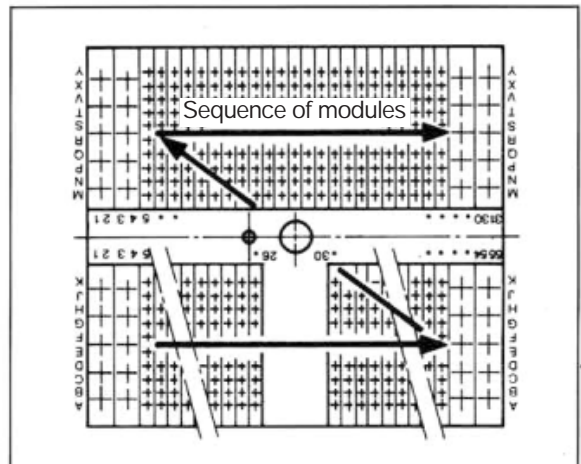
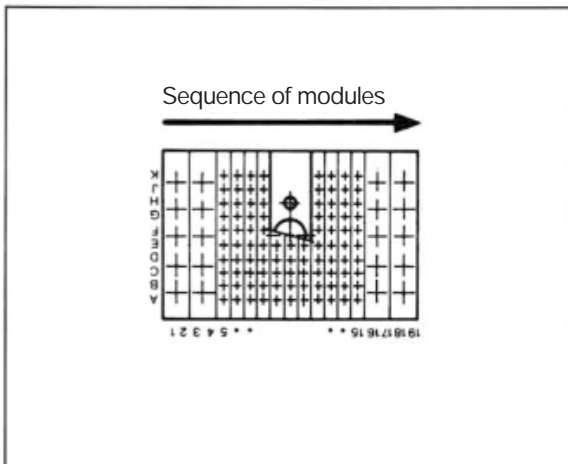

Dimensions are in mm

Panel mounting dimensions

For Single Row Frames

Frames: HB, HC, HD

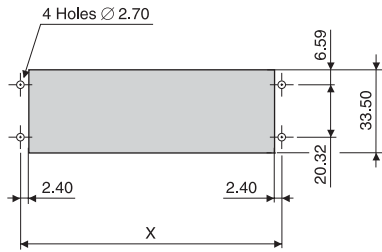

Frame: HG

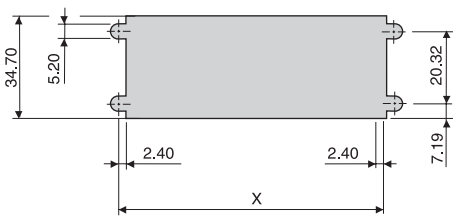

Frame: HH

Plug

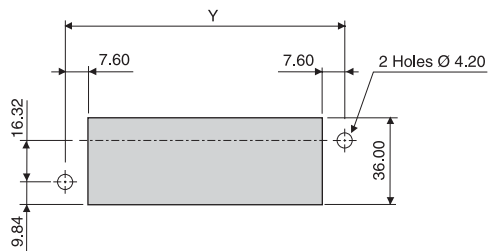

Receptacle

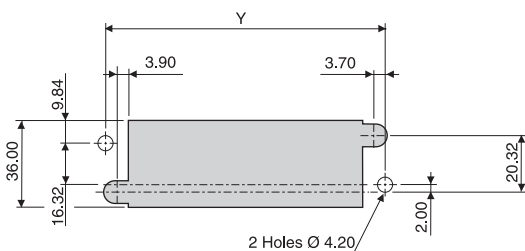

For Double Row Frame

Frame: HL 19 to 31 pitches

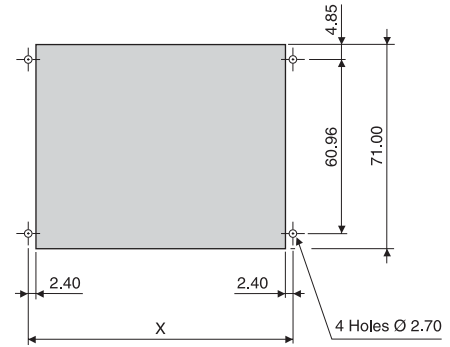

Frame: HL 35 to 55 pitches

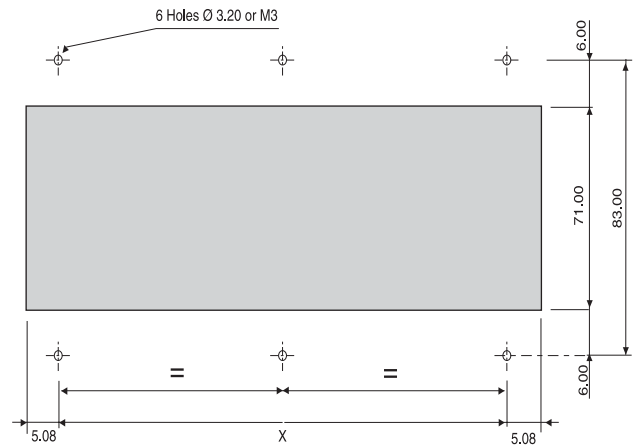

MOUNTING DIMENSIONS

FRAME UNITS	X	Y
7	25.40	50.80
11	35.56	60.96
15	45.72	71.12
19	55.88	81.28
23	66.04	91.44
27	76.20	101.60
31	86.36	111.76
35	96.52	121.92
39	101.60	
43	111.76	
47	121.92	
51	132.08	
55	142.24	

- Notes :
- 42 N.cm torque for mounting
  - Refer to individual frame type for standard length

Dimensions are in mm

